

## TUBULAR DRAG CONVEYORS

Tubular chain drag conveyor is the newest mechanical conveying option in our extensive line of mechanical conveyors designed for the dry bulk solids and powder processing industry.

- Deliver heavy-duty conveying
- Maximum layout versatility
- Maintain dust and contamination-free handling
- Keep your operation simple and operating costs low
- Lower your energy consumption
- Maximize your ROI
- Achieve fast, efficient conveying
- Minimize material breakage and maintain consistent mixtures
- Convey over long distances

KCTc tubular chain drag conveyor is the hygienic, heavy-duty, totally enclosed, dust-free economically conveys dry, hot (up to 248°F/120°C) or cold, powders and granules, particularly fragile materials such as cereals, nuts, coffee beans, food ingredients, pet food, animal feed, and a wide variety of chemicals and plastics.



## The control panel

The conveyor is equipped with a programmable control panel

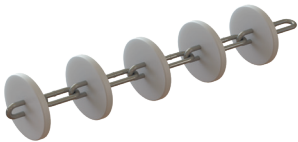

## Conveying chain

Conveyor chains are made of carbon or stainless steel with scrapers made of specialized plastic and scrapers made of stainless steel.

## Configuration options

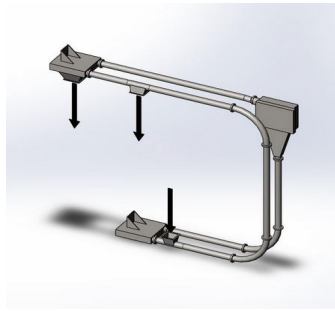

Model	Diameter scrapers, mm	Pipe diameter, mm	Step scrapers, mm	Engine speed, rpm	MAX vertical length, m	MAX horizontal length, m	Bulk density	Productivity M3
KCTc-89	75	89	96	1450	6	20	0,9	4,5
KCTc-114	100	114	104	1450	6	20	0,9	6
KCTc-159	145	152	160	1450	6	20	0,9	8,7

